



ダイカスト金型用チルベント 压铸模具用冷却槽

CHVEN

专利申请中



■ 材质：SKD61 ■ 硬度：48~52HRC
■ 表面处理：氮化处理

CHVEN50

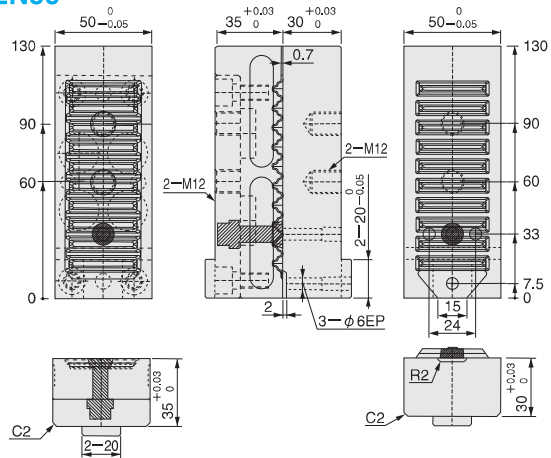

CHVEN80

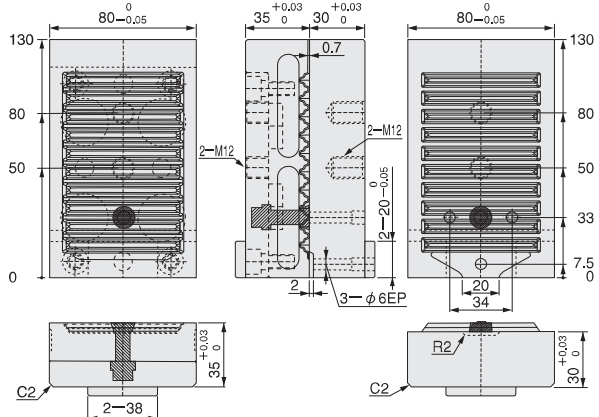

※斜线部分的固定销加工属于追加加工。

CHVEN110

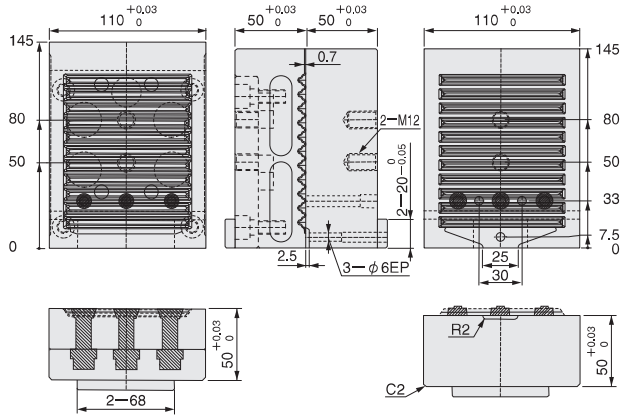

型号 Type	排气槽	最小 截面积 (mm ²)	L	W		D1(定模侧)			D2(动模侧)			Kw1 Kw2	KL1 KL2	Kv1 Kv2	Aa1 Aa2	Ab1 Ab2				
				尺寸	产品 公差	模具 公差	尺寸	产品 公差	模具 公差	尺寸	产品 公差						模具 公差			
CHVEN50	2	24.8	130	50	0	+0.1	35	+0.03	0	30	+0.03	0	-0.02	5	20	0	60			
CHVEN80		43.4		80											50			38	20	50
CHVEN110		65.1		145											110			50	68	20



型号
CHVEN50
CHVEN80



30 天发货



型号 — (FP·VH)
CHVEN50 — FP·VH
CHVEN80 — FP



询价联系方式:
<http://cn.misumi-ec.com>
TEL: 021-6710-8701 / FAX: 021-6710-8667
技术咨询请联系:
mold_sk@misumi.sh.cn
TEL: 021-5255-9388*6328

■ 特点

- 1: 排气性能
 - 将排气间隙变大提高其排气量
 - 用碟片弹簧的构造形式，使CHILLVENT(镶件)保持足够合模力度，防止PL面毛刺
- 2: 取出
 - 排渣时通过凸布的山形形状，可确保通过量均一化
 - 可以延迟汤料在CHILLVENT山形内流量速度
 - ⇒ 排渣处长度可变短
 - ⇒ 防止排渣处废料长度过长，防止折断，减少保养次数(压入E-Pin时容易折断)

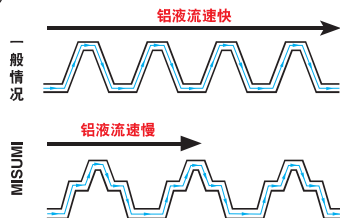

Alterations	Code	Spec.
	FP	加工固定销，确保可取出定模侧的铝渣 *CHVEN50/CHVEN80: 1处 *CHVEN110: 3处
	VH	对定模进行真空抽气加工 *CHVEN50.....PT1/4 *CHVEN80.....PT1/4 *CHVEN110.....PT3/8

■ 安装方法

